

System UNI® Dicht

System UNI® Dicht

Baumaße Pg

System dimensions Pg



Abb. 1
Fig. 1



Abb. 2
Fig. 2

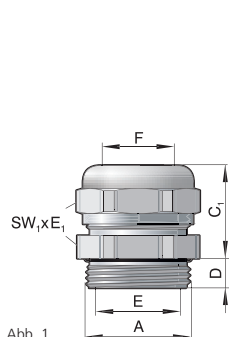

Abb. 3
Fig. 3

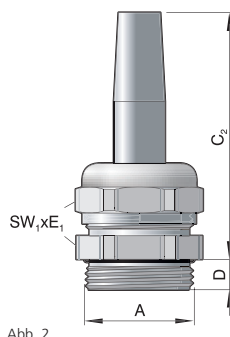

Abb. 4
Fig. 4

UNI Dicht Verschraubungen aus Messing (CuZn39Pb3) und Edelstahl (1.4305)

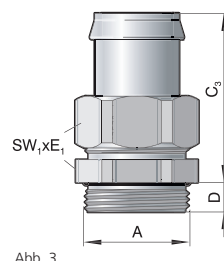
UNI Dicht cable glands made of brass (CuZn39Pb3) and stainless steel (AISI 303)

A	SW ₁ xE ₁	SW ₂ xE ₂	D mm	C ₁ mm	C ₂ mm	C ₃ mm	C ₄ mm	C ₅ mm	E mm	F mm
Pg 7	14x15,5	–	5,0	20	50	–	–	–	7,0	7,0
Pg 9	17x18,9	18x20	6,0	20	54	40	40	24,5	9,7	10,0
Pg 11	20x22,2	22x24,4	6,0	20	63	40	44	31,0	11,5	11,5
Pg 13,5	22x24,4	24x26,7	6,5	21	69	40	47	32,0	13,5	13,5
Pg 16	24x26,7	26x29	6,5	21	73	40	48	36,0	16,0	16,0
Pg 21	30x33,5	32x36,5	7,0	25	78	44	58	45,5	21,3	18,5/21
Pg 29	40x43,5	40x43,5	8,0	27	104	47	70	65,0	28,5	29,0
Pg 36	50x54	–	9,0	28	107	50	–	–	37,5	38,0
Pg 42	57x61	–	10,0	30	–	–	–	–	42,0	42,0
Pg 48	64x69	–	10,0	30	–	–	–	–	47,0	47,0
G 2 1/2"	81x87,3	–	15,0	40	–	–	–	–	64,0	59,5
G 3"	95x102	–	15,0	40	–	–	–	–	72,0	72,5

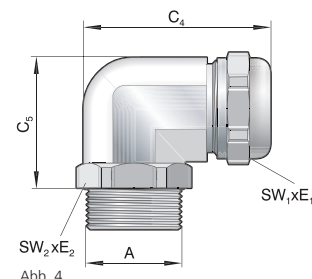
UNI Dicht Verschraubungen aus PVDF und PA

UNI Dicht cable glands made of PVDF and PA 6-3

A	SW ₁ xE ₁	D mm	C ₁ mm	C ₂ mm	C ₃ mm	C ₄ mm	C ₅ mm	E mm	F mm
Pg 7	15x16,5	8,0	23,0	–	–	–	–	7,0	6,8
Pg 9	19x21,2	9,0	23,0	55	41	38	23	10,0	10,0
Pg 11	22x24,4	9,0	23,5	64	42	42	25	11,5	11,0
Pg 13,5	24x26,5	9,0	24,0	72	42	46	30	14,0	13,0
Pg 16	27x29,5	9,0	24,0	76	42	52	33	16,0	16,0
Pg 21	33x36,5	11,0	29,0	80	46	–	–	21,0	21,0
Pg 29	43x46,5	11,0	33,0	104	50	–	–	31,5	28,0
Pg 36	53x57	14,0	33,0	110	–	–	–	37,0	37,0

Anschlussmaß Kabelverschraubungen – Pg

Connection dimension cable glands–Pg



Abb. 1
Fig. 1



Abb. 2 – bis auf Gewindeaußen-Ø (d2) ausgesenkt
Fig. 2 – up to major diameters of thread countersunk (d2)

Pg-Gewinde
Pg thread

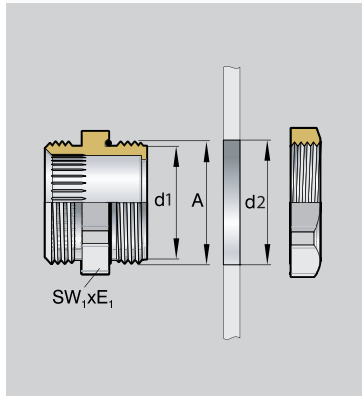
Pg-Gewinde Pg thread DIN 40 430	Kerndurchmesser Core diameter d 1 mm	Nennmaß Nominal Size Ø A mm	Steigung Pitch P	Durchgangsbohrung Bore through Ø d8 mm (0/+0,3mm)
Pg 7	11,28	12,5	1,27	12,5
Pg 9	13,86	15,2	1,41	15,2
Pg 11	17,26	18,6	1,41	18,5
Pg 13,5	19,06	20,4	1,41	20,5
Pg 16	21,16	22,5	1,41	22,5
Pg 21	26,78	28,3	1,588	28,5
Pg 29	35,48	37,0	1,588	37,0
Pg 36	45,48	47,0	1,588	47,0
Pg 42	52,48	54,0	1,588	54,0
Pg 48	57,78	59,3	1,588	59,5

Abb. 2: d2/A2 = Gewindeaußen-Ø
Fig. 2: d2/A2 = thread outer diameter

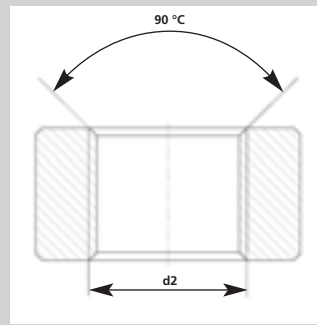
Anzugsmomente von Kabelverschraubungen

Tightening Torques of Cable Glands

Herstellerangaben für Anzugsmomente von Kabelverschraubungen nach EN 50 262 Für Wandungen mit Innengewinde und bei Durchgangsbohrungen mit Gegenmutter.

Manufacturer guideline for tightening torques of cable glands as per EN 50 262
Into a housing with female thread or in case of through holes into the lock nut

UNI Dicht Pg

UNI Dicht Pg

Gewindegrößen Thread size	Metall Metal	Kunststoff Plastic
Pg 7	6 Nm	2,5 Nm
Pg 9	8 Nm	4,0 Nm
Pg 11	10 Nm	4,0 Nm
Pg 13,5	10 Nm	4,0 Nm
Pg 16	10 Nm	6,0 Nm
Pg 21	15 Nm	8,0 Nm
Pg 29	20 Nm	10,0 Nm
Pg 36	30 Nm	15,0 Nm
Pg 42	30 Nm	15,0 Nm
Pg 48	40 Nm	15,0 Nm



Tabellenwerte sind allgemeine Vorgaben. Das Drehmoment hängt vom verwendeten Kabel und der Einsatzdichtung ab, sollte aber die in der Tabelle angegebenen Werte nicht überschreiten.

Table figures are general terms of reference. The torque depends on the cable used and the insert sealing; it should not, however, exceed the figures stated in the table.